

Multi Ratio

ET223Q(IB) Installation guide

Mounting method I

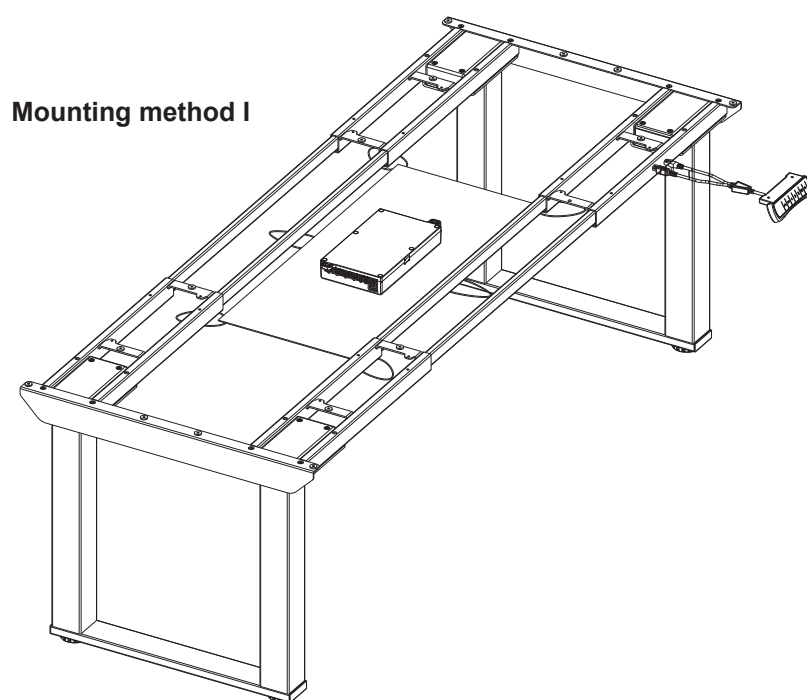

Mounting method II

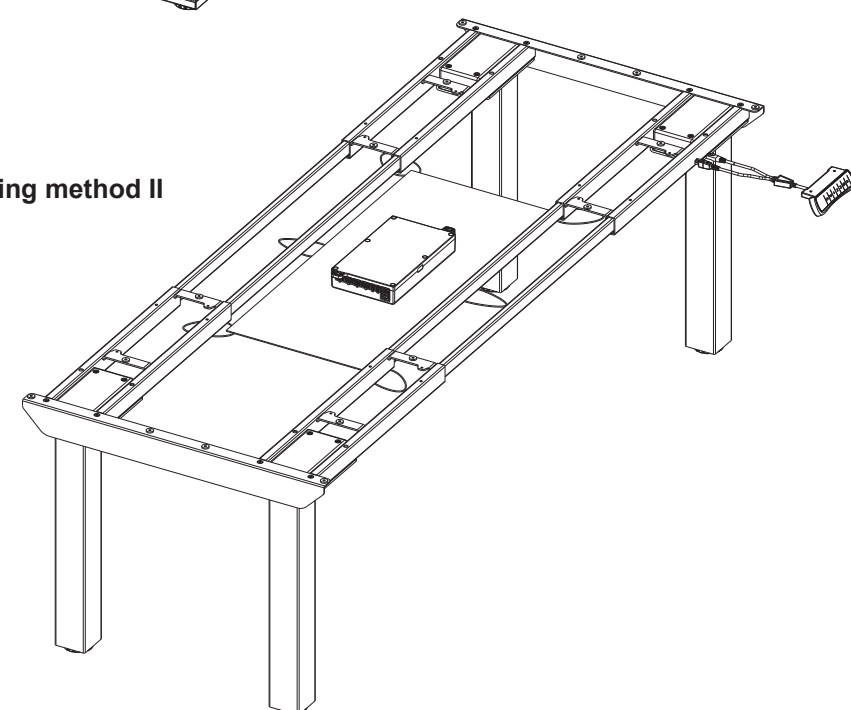

< The pictures below are for reference only, please refer to the actual product. >
Please read this product manual carefully before use, and keep it properly.

Technical Data

Max. Load Capacity	200KG
Max. Speed	38mm/s
Highest Position	605mm
Lowest Position	1255mm
Width Range	1100mm-1900mm
Applicable Desktop Size	Length: 1800mm-2400mm
	Width: 800mm-900mm

Product List

Accessory List

Attention: The drawings below are for guidance only and they may differ slightly from the product and fittings received. Please contact customer service if there are any missing tools or installation problems.

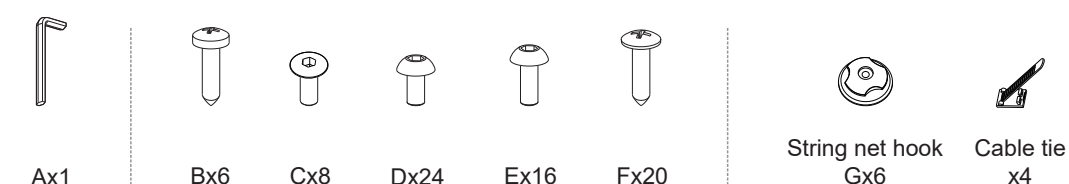

Preparation before installation

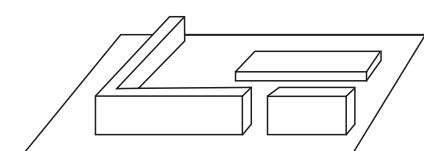

Install on carpet to prevent scratches.

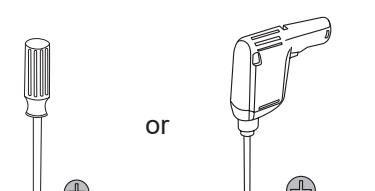

Bring your own Phillips screwdriver or pistol drill.

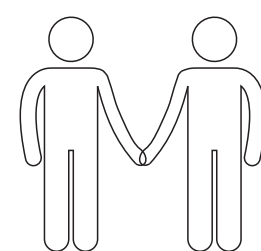

Need two or more people to cooperate together.

Part List

No.	Part
①	Supporting beam x2
②	Side bracket x2
③	Lifting column x4
④	Foot x2
⑤	Handset x1

No.	Part
⑥	Control box x1
⑦	Power Plug x1
⑧	Cable management net x1
⑨	Foot Pad x4

Installation Instruction

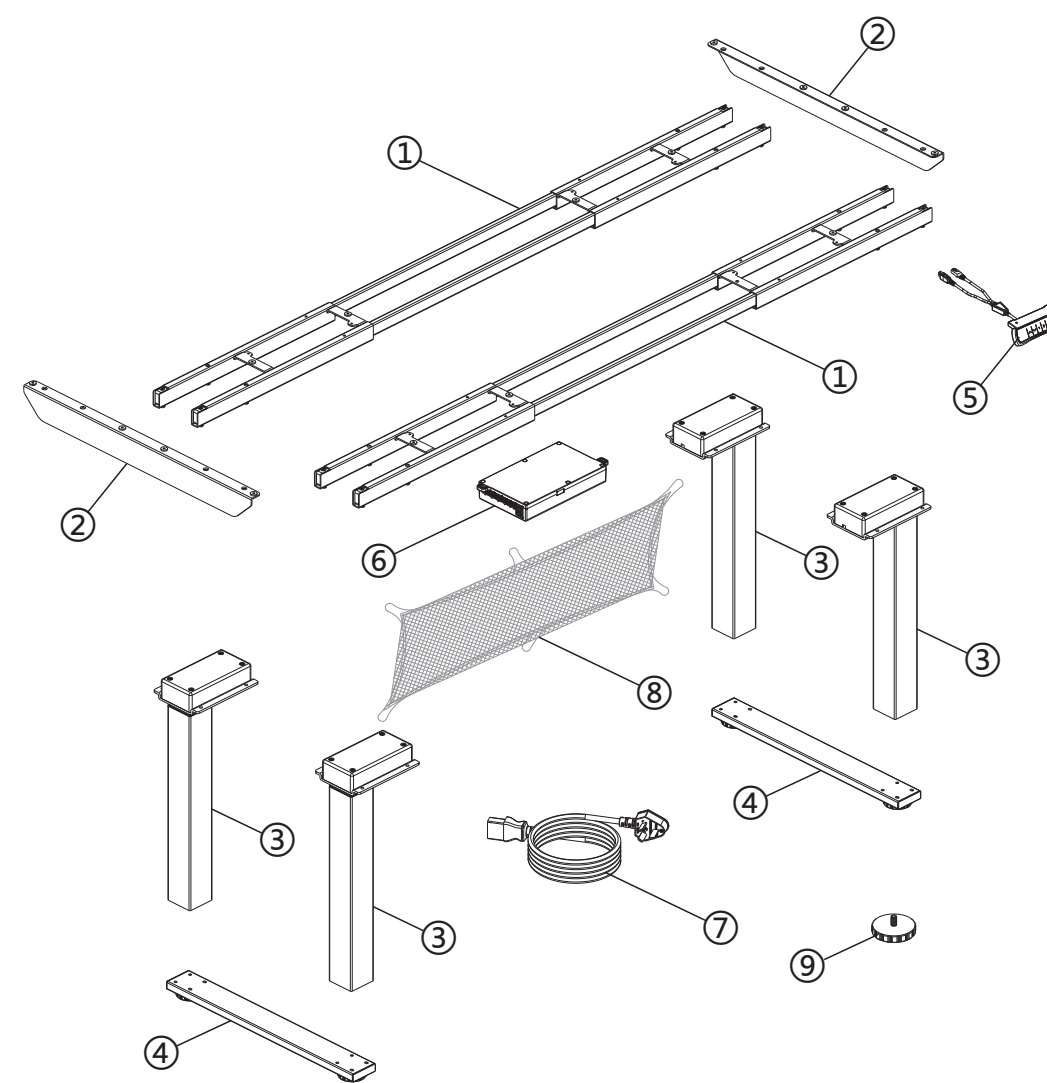

Installation Steps

STEP1

Attach the side brackets to the beam

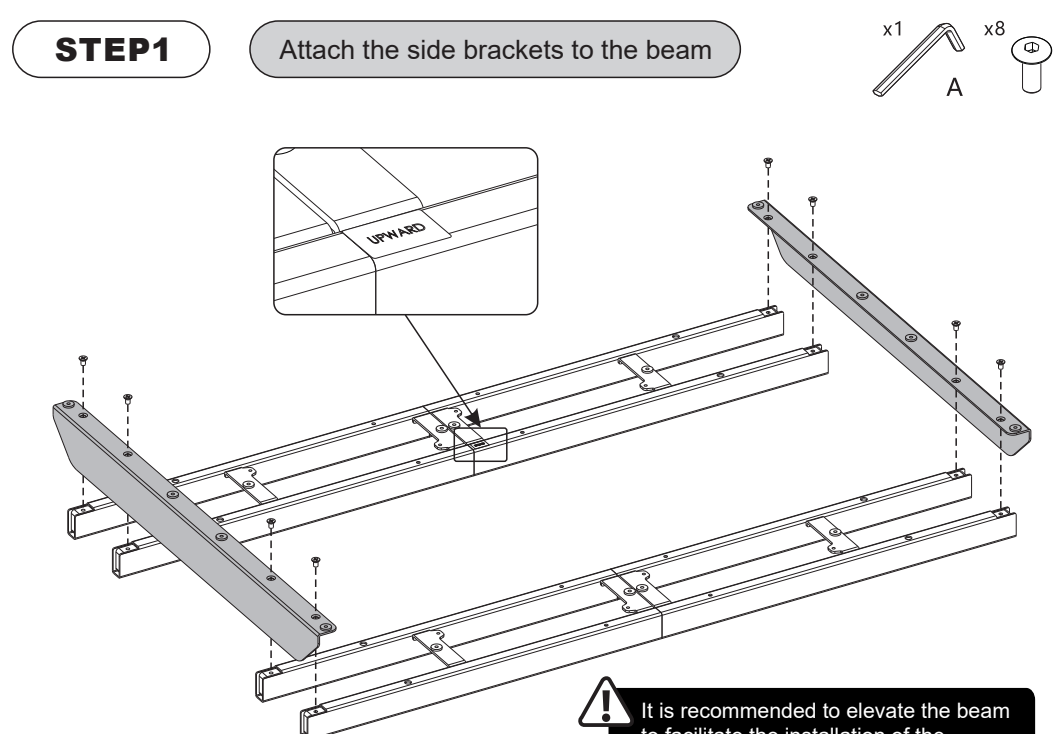

STEP2

Adjust the length of the supporting beam

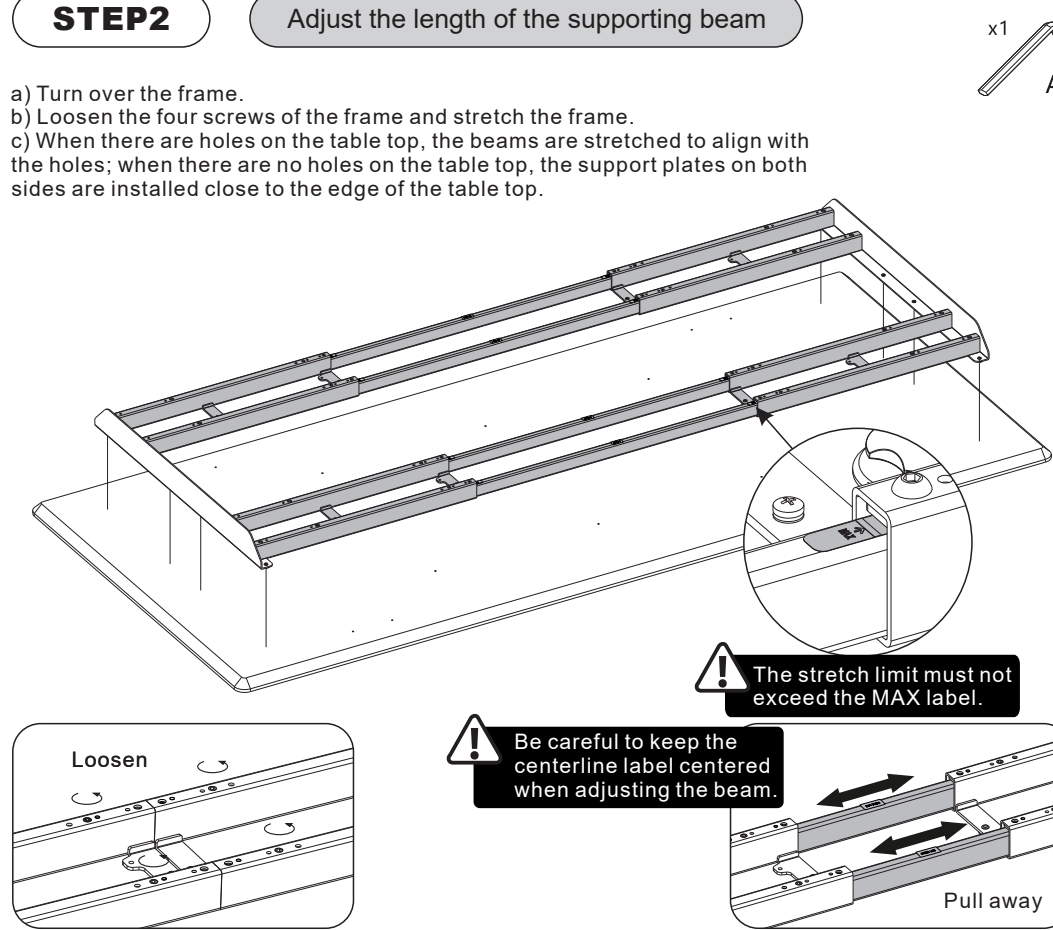

STEP3 Install the tabletop

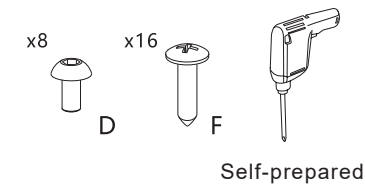

Fix the screws in the sequence of: ● → ■

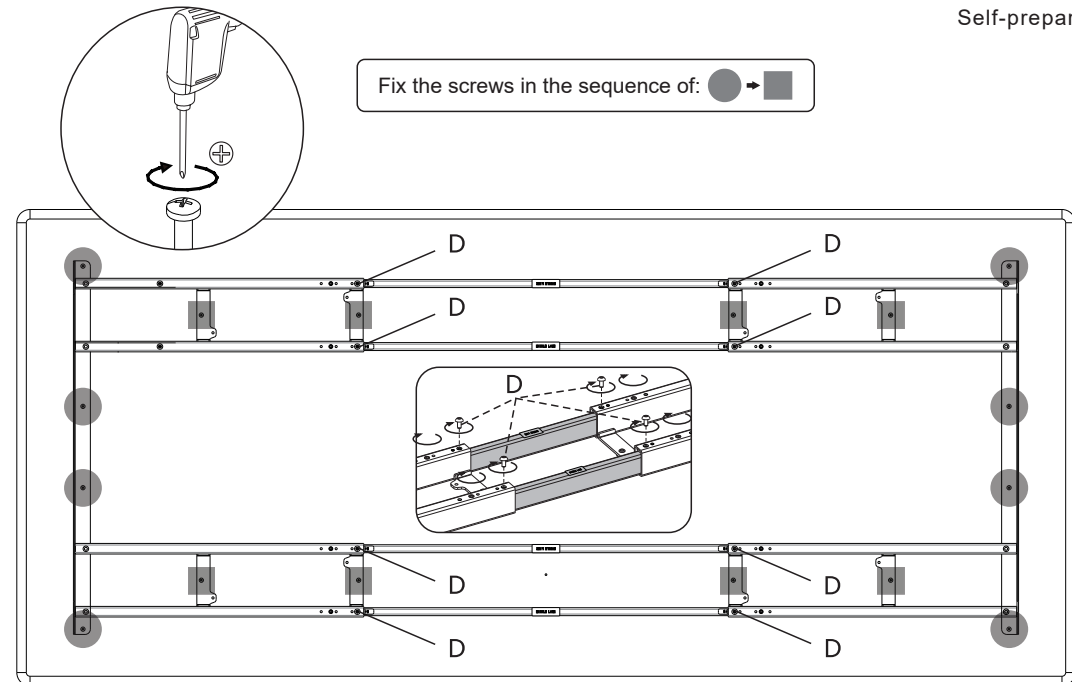

STEP4 Install the lifting columns

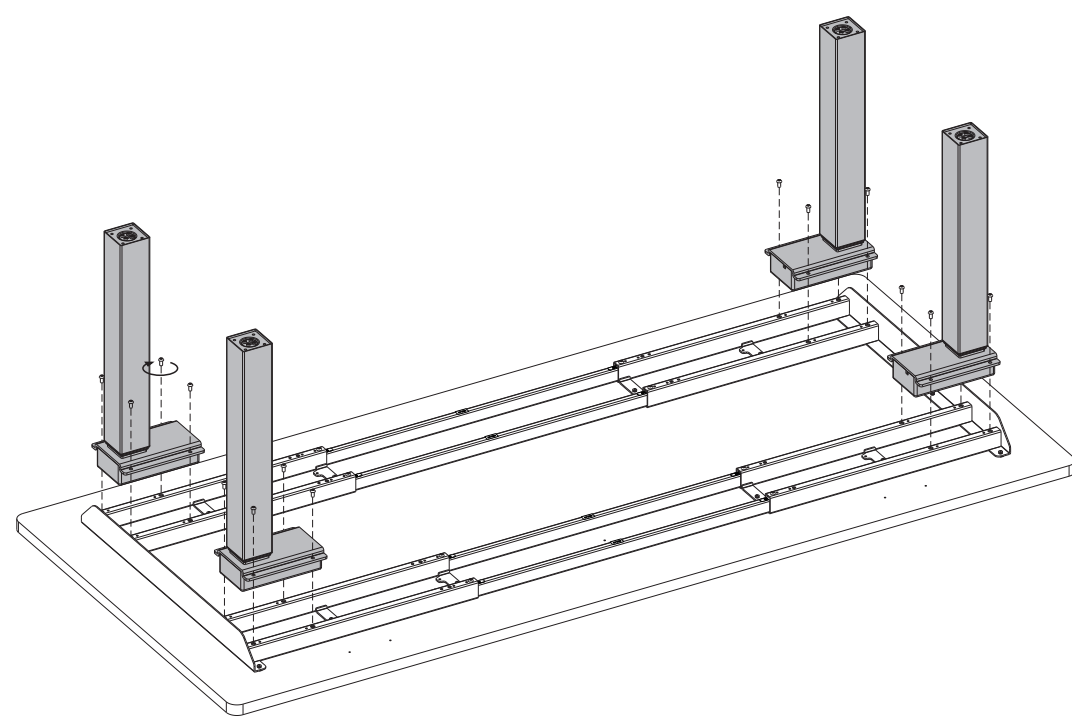
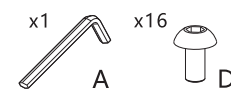

STEP5-1 Attach the feet I

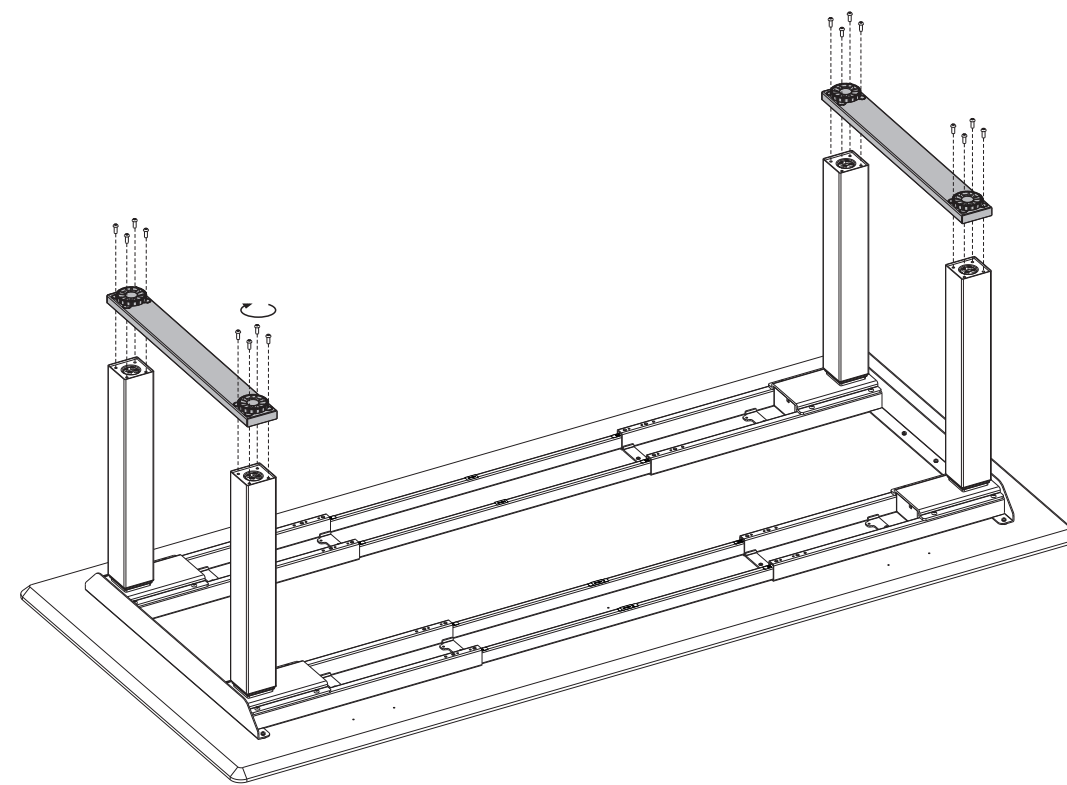
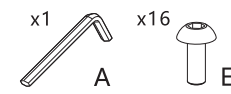

STEP5-2 Attach the feet II

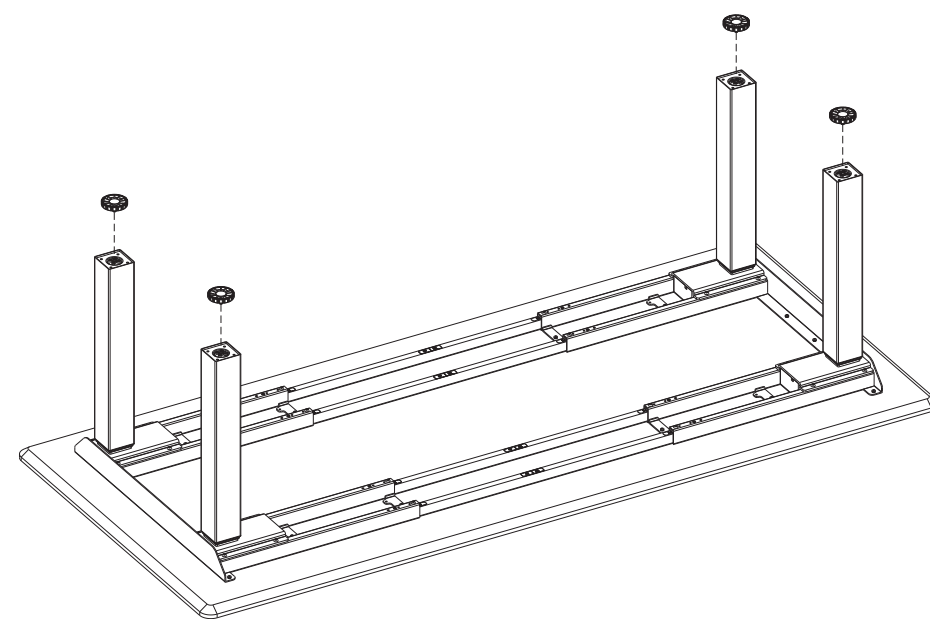

STEP6 Install Handset

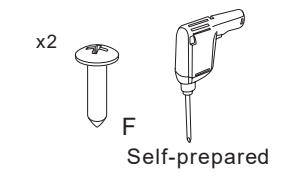

! You can install the handset on either edge depending on your hand preference.

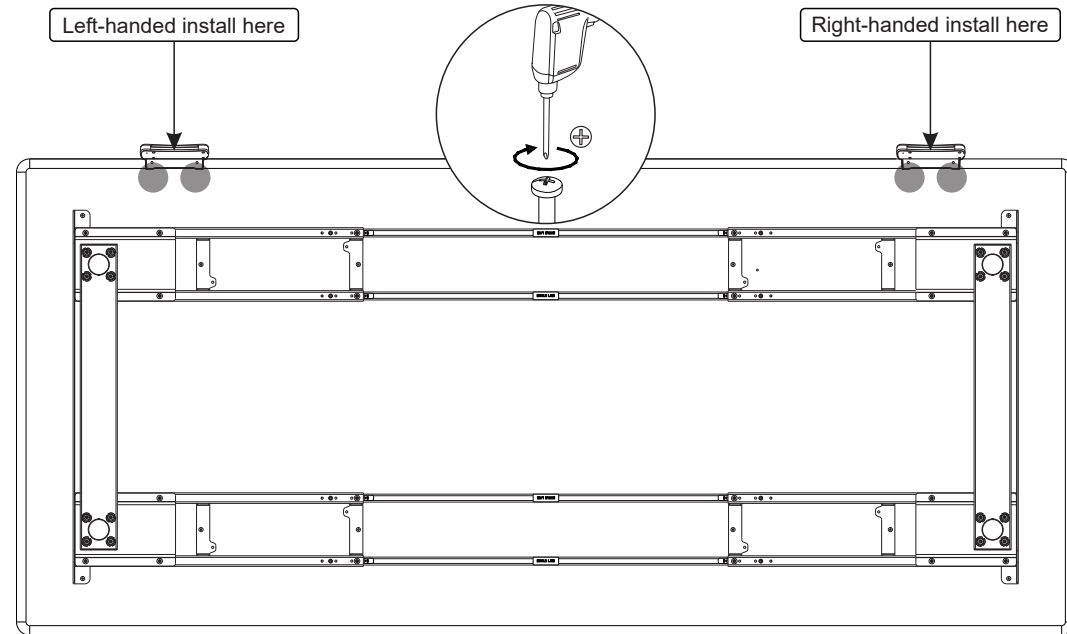

STEP7 Attach the control box

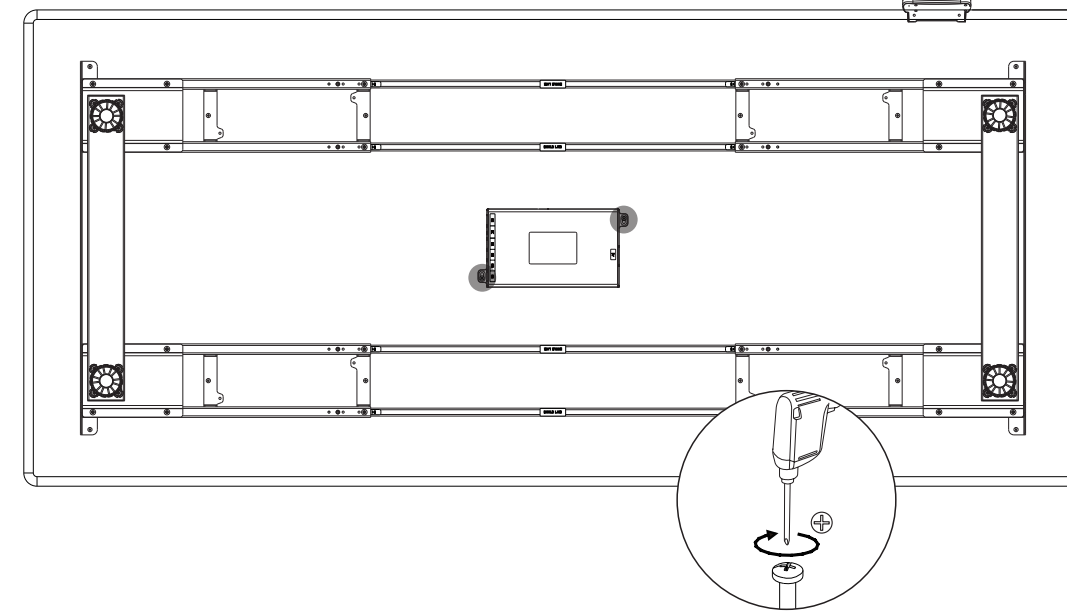
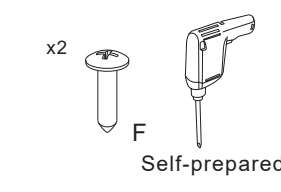

STEP8 Connect the wires

! Connection of the same color.

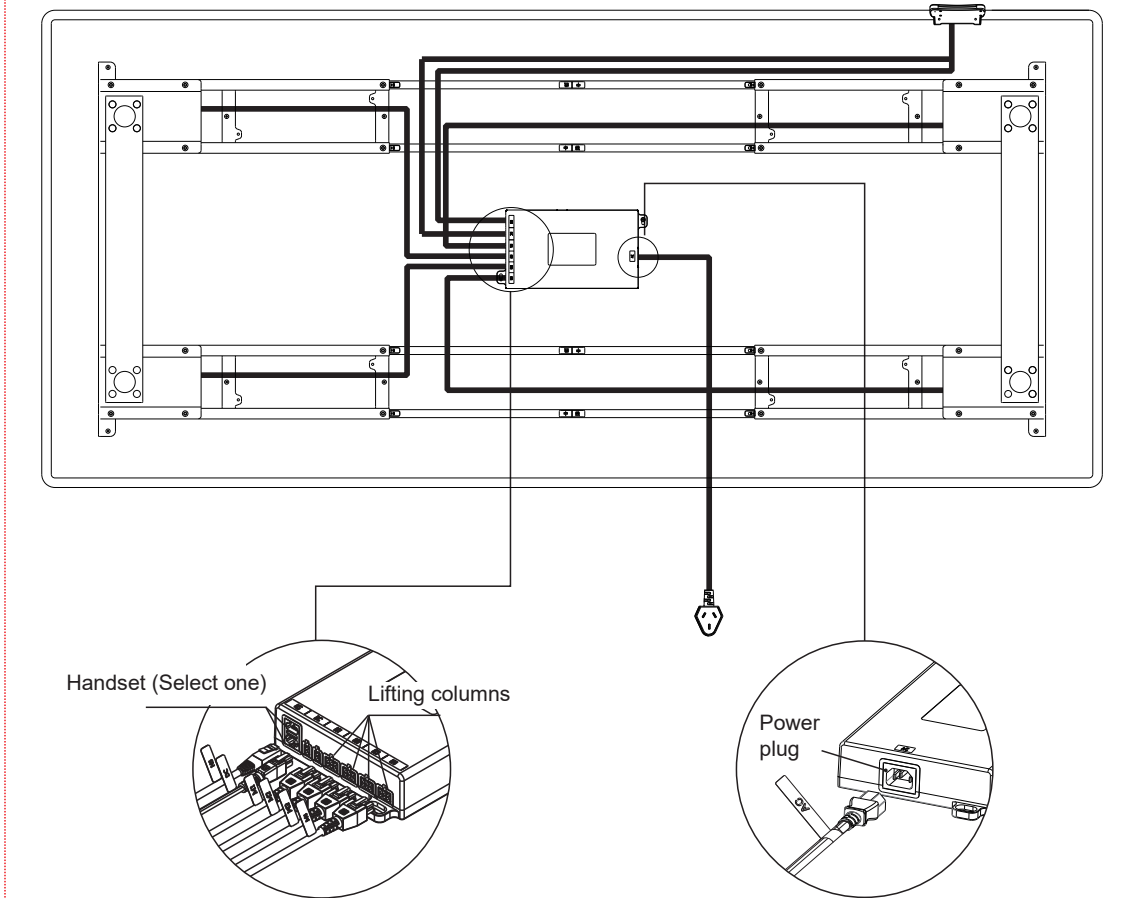

STEP9 Install the string net hook

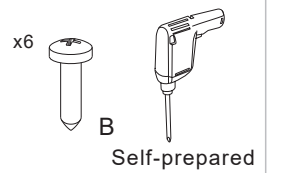

! When the table board has holes, the position of the hook is charity according to the holes;
When the table board has no holes, the net can be laid flat to determine the position of the hooks.

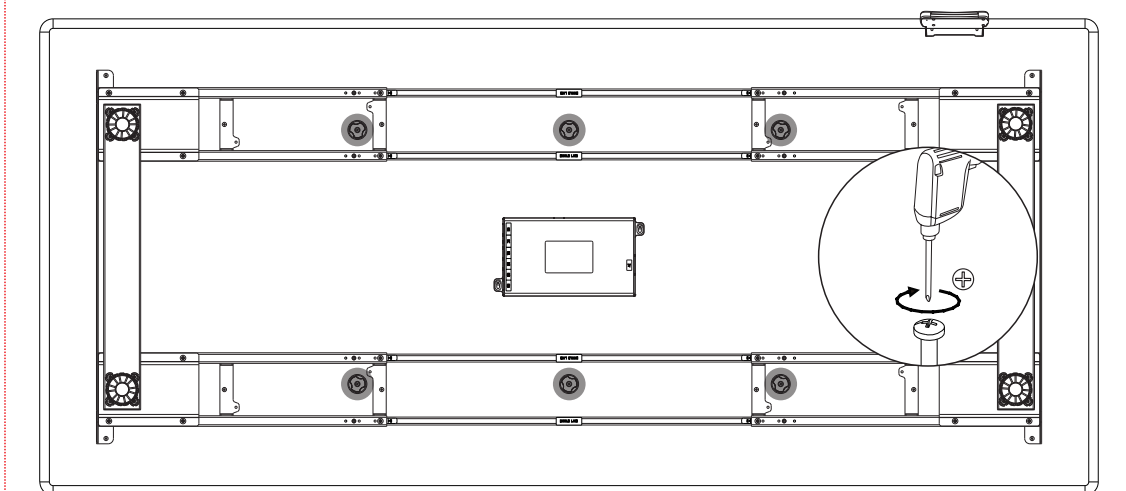

STEP10 Attach cable management net

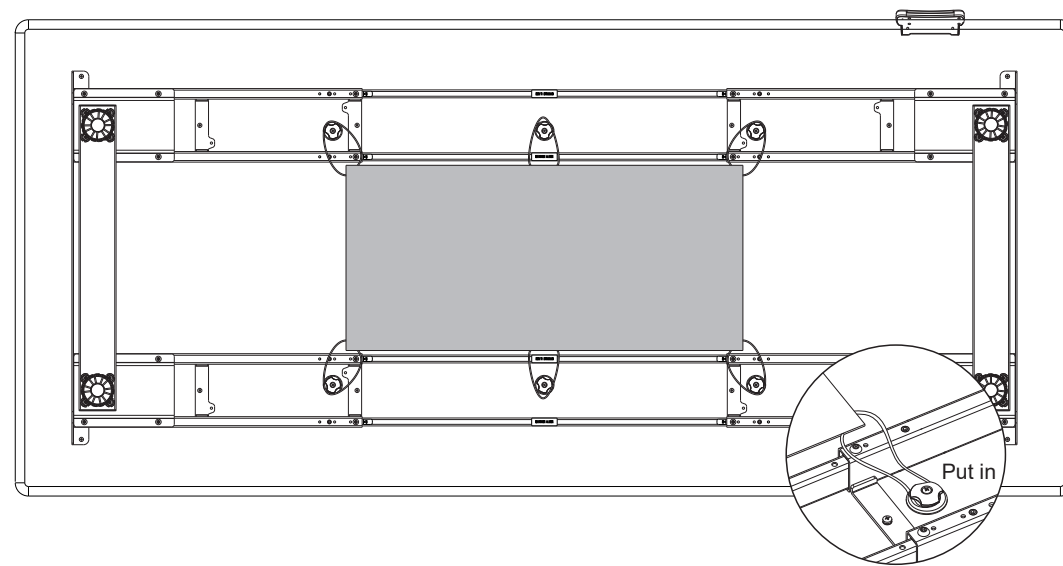

⚠ Turn over the desk, make sure the handset is facing upwards along the process.

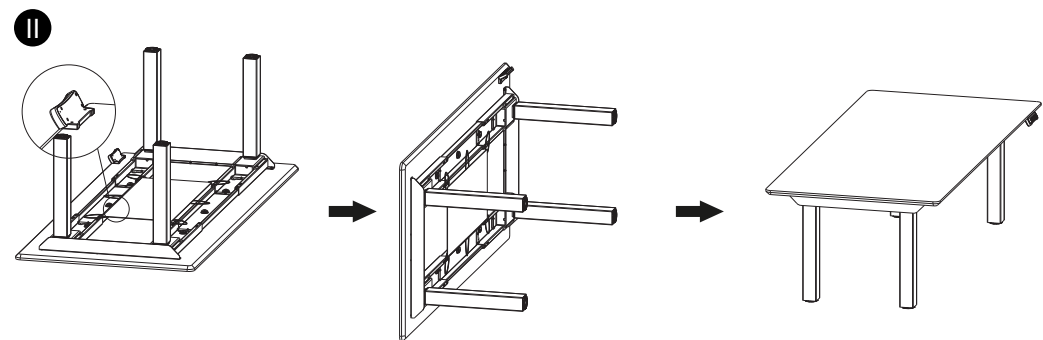
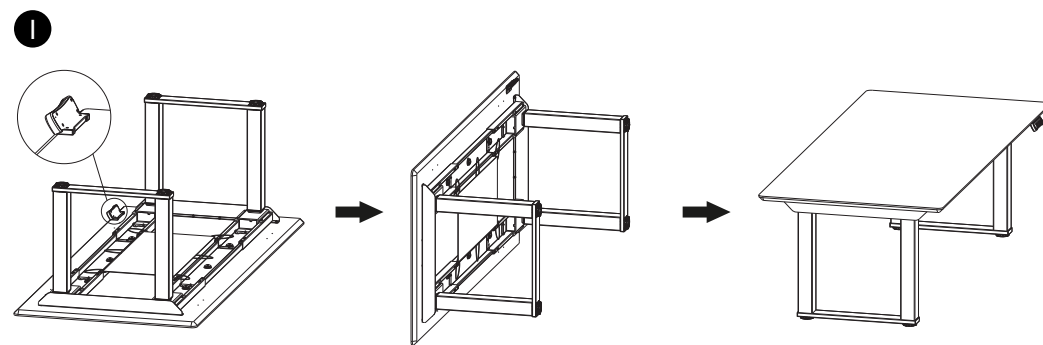

Common fault treatment

The following tips will help you detected and eliminate the common fault and error. If the fault you met is not listed below, please contact with your supplier. Only the manufacturer and professionals are capable for investigating and correcting those fault and error.

Fault phenomenon	Method
The desktop could not function	Check if all the cables well connected;
Rising in a low speed	Check if overloaded, max loading: 200kg;
The desk moving downwards without any operation	
Automatically Self-Reset	Reset;
Go down but not go up or go up but not go down	
The upper and downward height is not enough	
The desk could not lifted	Restart after suspend for 18mins while connecting with power.
Overwork (Duty cycle: Max 2min on/18min OFF)	
Press "▼"button while desk rises	Check whether there are barriers beneath the table or cables are entwined with other things.

Attention

1. Power supply: AC100V-240V, 50/60Hz
2. Service Environment: 0-40°C
3. Unplug the power plug before cleaning, wipe the dust on surface with slight wet dishcloth when cleaning, be careful not to let the drops into the internal parts, not loose the connector.
4. The electric box contains electronic components, metals, plastics, wires etc., so dispose of it in accordance with each country's environmental legislation, not the general household waste.
5. Check carefully to ensure correct and complete assembly before using.
6. Be familiar with all functions and program settings of the product before first use.
7. Children are forbidden to play on the product because of unforeseen action when playing, so any dangerous consequences caused by this improper action will not be on manufacturers.
8. Slight noise caused by the V-ribbed belt or brake system due to structure will not have any effect on the use of the equipment.
9. Corrosive or abrasive materials are forbidden to clean the equipment. Must ensure that the cleaner used will not pollute the environment.
10. This appliance can be used by children aged from 8 years and above and persons with reduced physical, sensory or mental capabilities or lack of experience and knowledge if they have been given supervision or instruction concerning use of the appliance in a safe way and understand the hazards involved. Children shall not play with the appliance.
11. Cleaning and user maintenance shall not be made by children without supervision.
12. If the supply cord is damaged, it must be replaced by the manufacturer, its service agent or a similarly qualified person in order to avoid a hazard.
13. Please make sure there is no hazard sources in your operating environment. e.g., do not litter the tools around. Always be careful to treat the packaging materials in order to avoid any possible danger, e.g. plastic bag may lead to choking hazard to children.
14. Keep the original package of the equipment if necessary in case of the future use in transportation.

Waste disposal



This marking indicates that this product should not be disposed with other household wastes. To prevent possible harm to the environment or human health from uncontrolled waste disposal, recycle it responsibly to promote the sustainable reuse of material resources. To return your used device, please use the return and collection systems or contact the retailer where the product was purchased. They can take this product for environmental safe recycling.



Multi Ratio B.V.
Plakhorstweg 46, 7008 AT Doetinchem
T: 0314 - 399 088
E: info@multiratio.nl